



INDEX

S N.	Contents	Pages
1.	Some Pencil Shading Techniques	3
2.	Perspective Drawing	4
3.	Pencil Shading	5
4.	Pencil Shading	6
5.	Object Drawing	7
6.	Insects	8
7.	Hair Style and Features	9
8.	Bird Drawing Step-Wise	10
9.	Ship (pastel Colours)	11
10.	Pattern Drawing	12
11.	Sketch The Pattern	13
12.	Drawing Animals (Template Techniques)	14
13.	Sun craft	15
14.	Water Colour	16
15.	Water Colour	17
16.	Kettle	18
17.	Boy (Water Colour)	19

S N.	Contents	Pages
18.	Flowers	20
19.	Facial Expressions	21
20.	Nature	22
21.	Nature	23
22.	Knife Painting	24
23.	Giraffe	25
24.	Landscape Poster & Crayons	26
25.	Birthday Card Pencil Colour	27
26.	Tree Thumb Impression / Fish	28
27.	Landscape (Water Colour)	29
28.	Roses / Cactus (Fun with Colour Pencils)	30
29.	Brush Spray Painting	31
30.	Sketch Pen	32



Some Pencil Shading Techniques

Some important pencil shading techniques are mentioned here.

FACT FILE

The current record holder for biggest pencil in the world is in Malaysia.

Repetition : By repeating our pencil strokes, we may get different types of patterns and textures. We divide this technique into three parts : (i) Etching, (ii) Cross etching and (iii) scribbling.

Etching :



Light etching



Dark etching



Darker etching

Small short strokes may be slanted, usually drawn in a downward direction. We may add more pressure and more repetition to get a dark shade.

Cross etching :

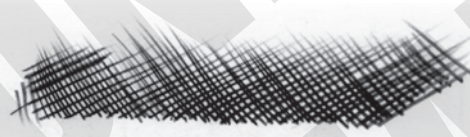
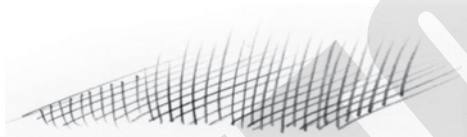

Cross etching is done by shading lines in such a way that all lines cross each other to create a darker shade and desired effect.

Scribbling :

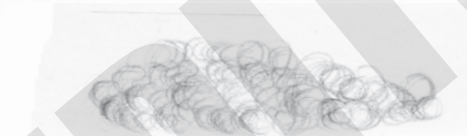

Light scribbling

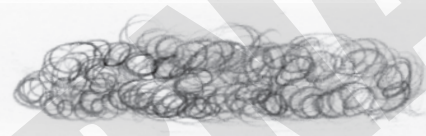

Medium scribbling

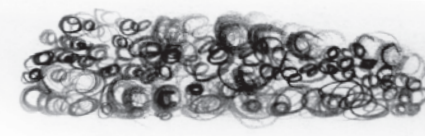

Dark scribbling

Scribbling is done by applying the pressure to the pencil. We may give more pressure and repeat scribbling to get darker type of scribbling.

Smudging



A piece of cotton cloth or a piece of cotton is used for smudging. It makes our work much easier, less time consuming while shading big sketches and making even shading effects.

Excellent		A	Good		B	Fair		C
	<input type="checkbox"/>			<input type="checkbox"/>			<input type="checkbox"/>	

Teacher's Remark



Perspective Drawing

The art of drawing solid objects on a two dimensional surface so as to give the right impression of relative position, size etc. from a particular distance as they appear to viewer's eye level is called 'Perspective Drawing'. Due to perspective, objects look bigger at front and appear to be small as they move away and seems to vanish at the point called vanishing point.



Let Me Answer

- *What do you mean by word Vanishing?
- *Can you state the reason why some of the trees do not have leaves?

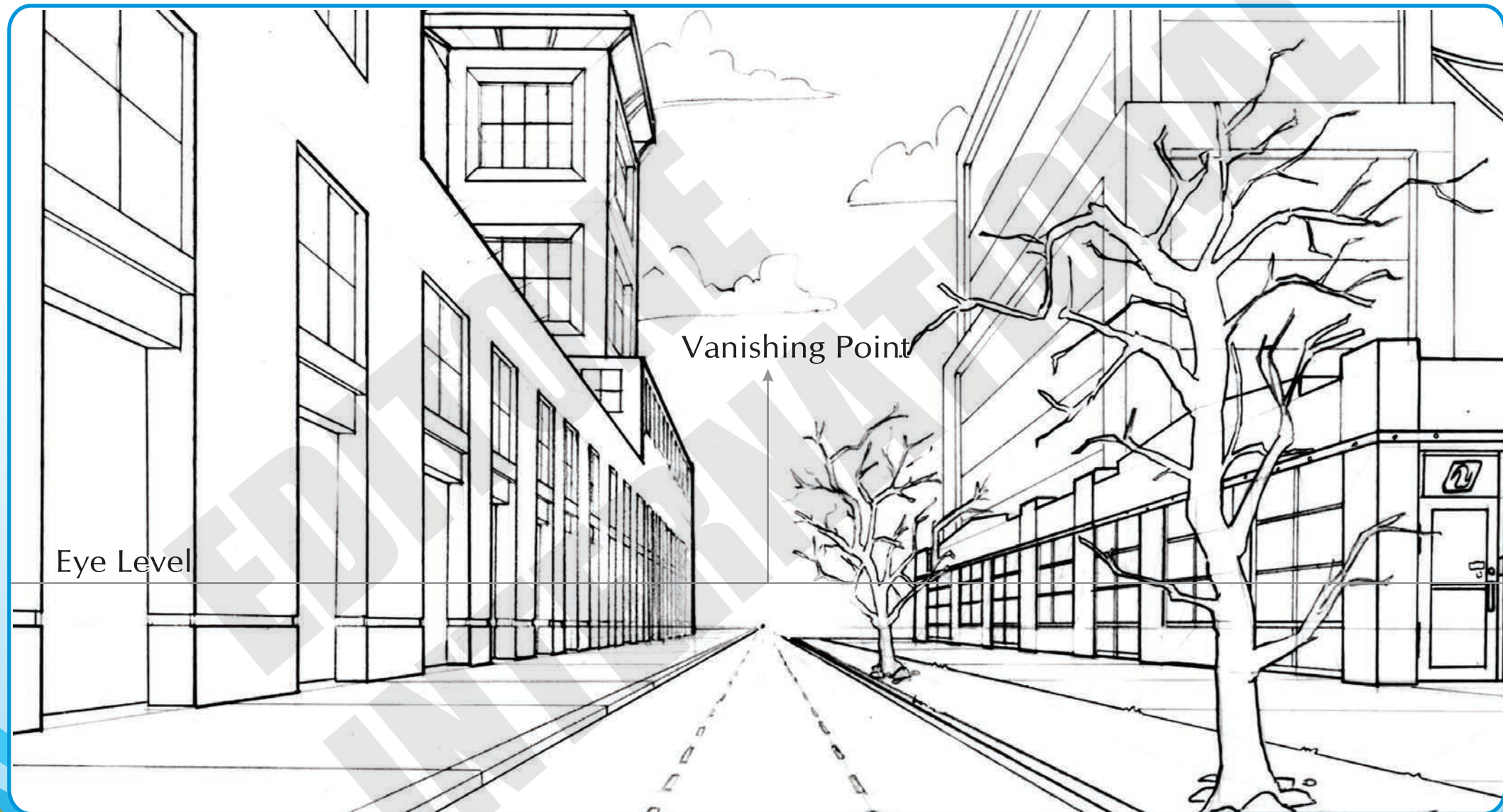



Pencil Shading

You must have seen these things in your house. Look at them carefully and draw them with the help of geometrical shape. Shade them nicely.



Let Me Answer

- * How many players are on a football team?
- * What do you like most about your birthday?

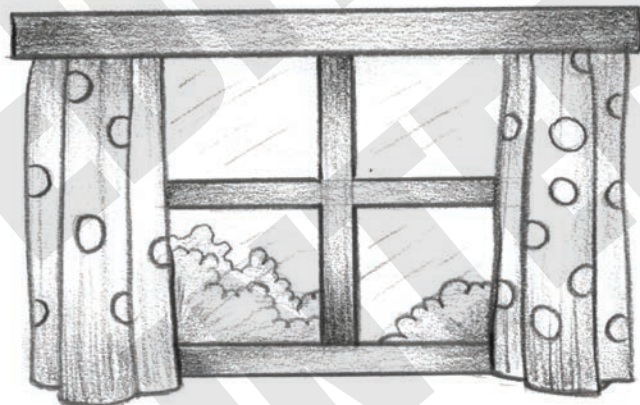
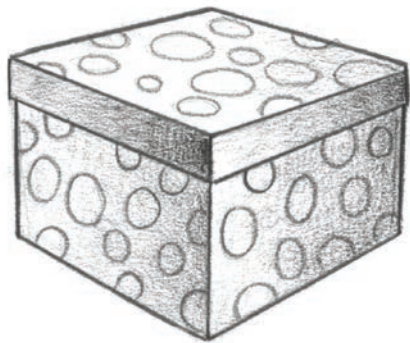

Excellent A Good B Fair C

Teacher's Remark





Pencil Shading

With the help of pencil, draw and shade various utensils in the space provided on the right side.



Let Me Answer

- * What are the five kinds of materials of utensils?
- * Which utensil do you like?





Object Drawing

Use the simple method of frames to draw these objects.

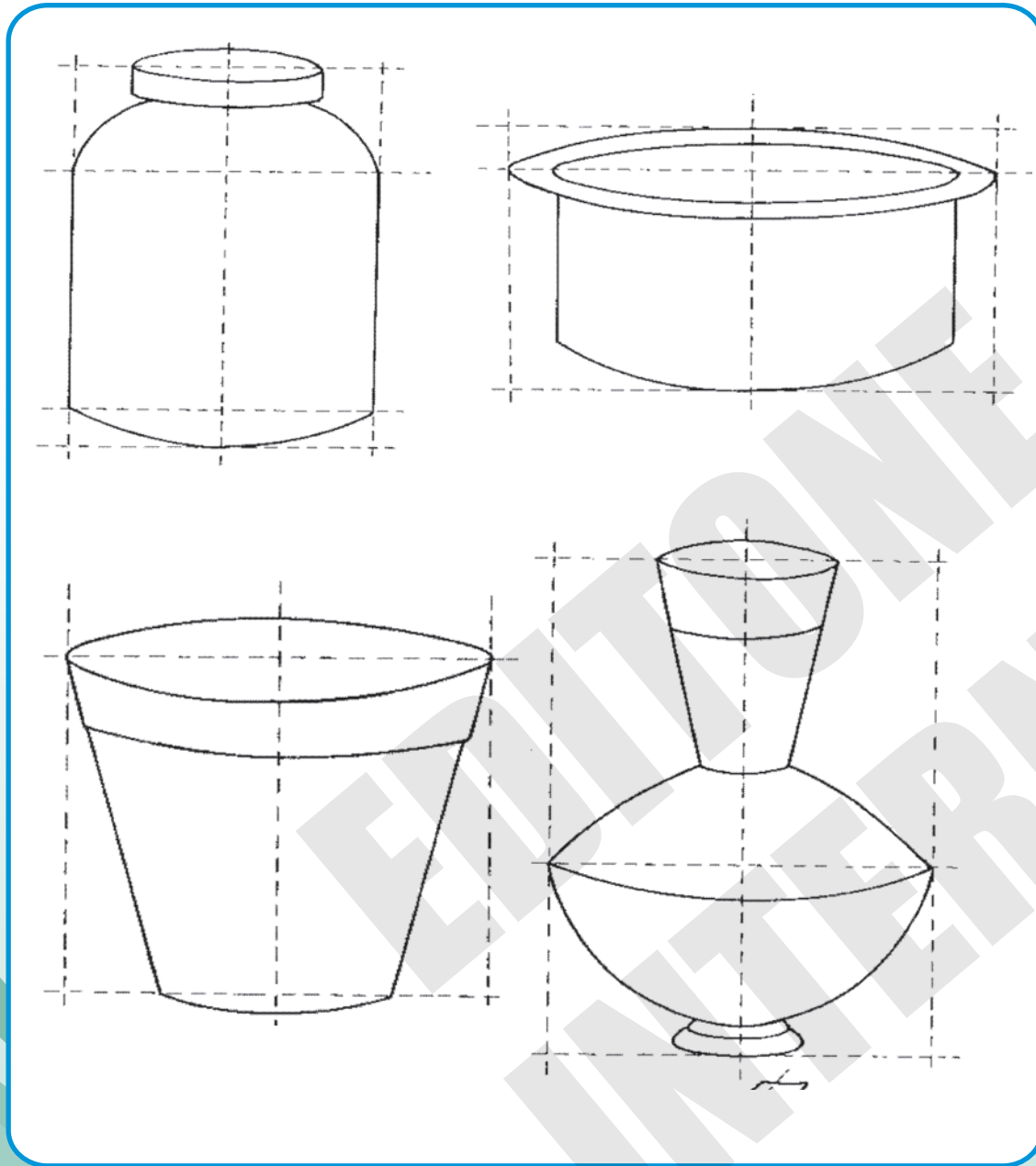

Let Me Answer

- * Apart from filling the water, for what purpose do you use buckets?
- * Why we use a container?

Excellent A Good B Fair C Teacher's Remark



Insects

Use black pen to fill life into these insects.



Let Me Answer

- *Where are ladybug commonly found?
- *How many wings does a house fly have?

